

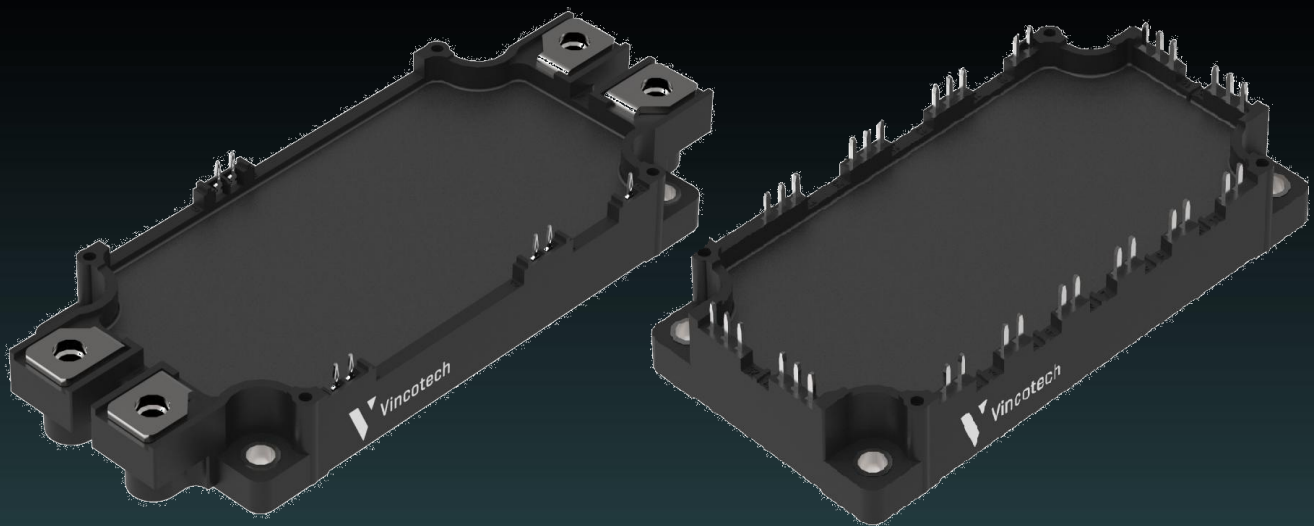

Vincotech

# Handling Instructions

for VINco E3 packages



*This document is valid for all type of VINco E3 modules:  
Solder & Press-fit pin versions*

**Date:** 29.05.2019

**Revision:**

**Created by:** M. Géczy

**Rev. 04**

**Proprietary data, company confidential. All rights reserved.**



## Table of Contents

<b>1 General instructions</b>	<b>5</b>
<b>2 Specification for the driver PCB</b>	<b>5</b>
2.1 Specification for modules with Press-fit pins that are soldered to the PCB	6
<b>3 Specifications for baseplate</b>	<b>6</b>
<b>4 Specifications for heat sink</b>	<b>7</b>
<b>5 Specifications for thermal interface materials</b>	<b>7</b>
5.1 OPTION 1: Thermal paste	7
5.2 OPTION 2: Pre applied thermal interface material	7
<b>6 Specifications for fastening screws to the heat sink</b>	<b>8</b>
<b>7 Screw specification for fastening main terminals to bus bars</b>	<b>8</b>
<b>8 Press in process of modules with Press-fit pins</b>	<b>9</b>
8.1 Press-in construction	9
8.1.1 Press-in tool for modules without thermal interface material	10
8.1.2 Modules with thermal interface material	10
8.1.3 Supporting tool	10
8.2 Press-fit process control parameters	11
8.3 Disassembling a driver PCB	12
8.3.1 PCB larger than Module	12
8.3.2 PCB not larger than Module	14
<b>9 Recommendation for soldering</b>	<b>14</b>
9.1 Wave soldering of modules with solder pins	15
9.2 Hand soldering parameters	15
<b>10 ESD protection</b>	<b>15</b>
<b>11 Environmental conditions</b>	<b>16</b>
11.1 Storage, transportation and operation conditions	16
11.1.1 Climatic conditions	16
11.1.2 Biological conditions	17
11.1.3 Chemically active substances	17
11.1.4 Mechanically active substances	17
11.1.5 Mechanical Conditions	17
11.2 Handling of trays	19
<b>12 Disclaimer</b>	<b>19</b>



## Table of Figures

Figure 1: Module with driver PCB and heat sink.....	5
Figure 2: Height of the module.....	5
Figure 3: Scratch dimensions.....	6
Figure 4 (left to right): Polished surface; Discoloration; Fingerprint .....	6
Table 1: Thermal paste thickness .....	7
Table 2: Phase change material thickness.....	8
Figure 5: Screw positions in sequence.....	8
Figure 6: Recommended setup for press-fitting .....	9
Figure 7: Module with PC-TIM (left); Press-in tool for modules with PC-TIM (right) .....	10
Figure 8: Recommended dimensions for the press-in supporting tool .....	11
Figure 9: Typical press-in diagram of a module with 7 pins.....	12
Figure 10: Recommended setup for disassembly .....	13
Figure 11: Typical press-out diagram of a module with 7 pins .....	13
Figure 12: Cutting edge .....	14
Figure 13: Plated through hole, well soldered .....	14
Figure 14: Typical profile for wave soldering .....	15
Figure 15: Layer of trays .....	19



## Revision History

<b>Date</b>	<b>Revision Level</b>	<b>Description</b>	<b>Page Number(s)</b>
29.05.2019	04	Mounting torque, Press-fit curves and parameters, Operating conditions, handling of trays	8, 11, 12, 13, 16, 17, 19
28.03.2017	03	Sixpack extension	1, 5
02.11.2016	02	First release	
06.09.2016	01	Preliminary release	



## 1 General instructions

Figure 1 shows the basic assembly of a VINco DUAL E3 module. It is attached to a heat sink with thermal interface material. A driver PCB is mounted on the top of the module with screws. Electrical connections between the module and driver PCB are soldered or press-fitted. The main terminals are fastened to bus bars using the screw types specified in section 7.

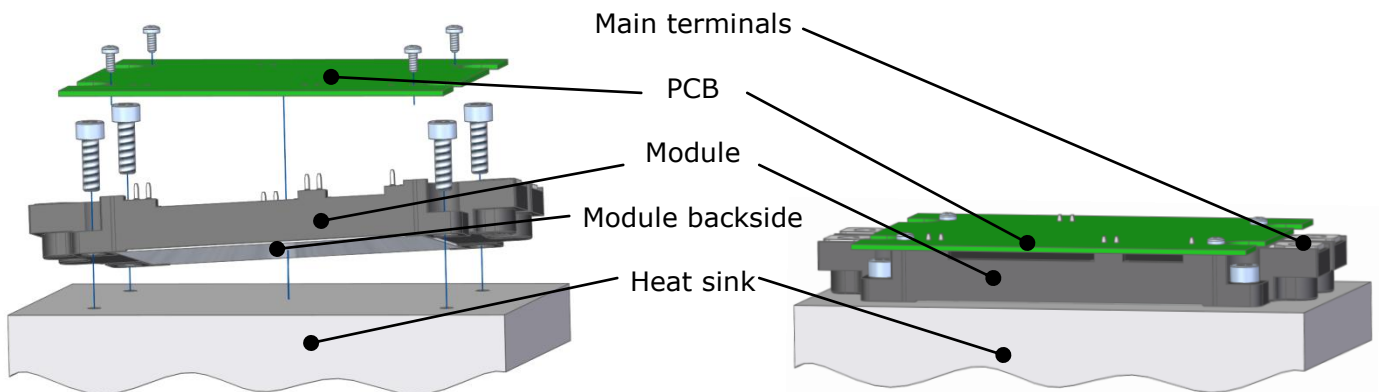

Figure 1: Module with driver PCB and heat sink

The distance between the heat sink surface and the driver PCB is defined by the module height which is  $17 \text{ mm} \pm 0.2 \text{ mm}$  centered on the pinhead as shown in Figure 2.

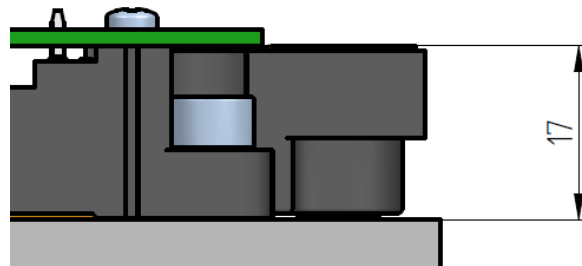

Figure 2: Height of the module

Typical (recommended) assembly sequence:

1. Attach the module to the PCB
2. If necessary use spacers position and fix the assembled PCB to the heat sink
3. Fix the module to the heat sink
4. If available fix the power screw connections to main terminals

## 2 Specification for the driver PCB

There is no limit as to the maximum number of conductive layers. The driver PCB should be attached to the module with four BN82428 type screws ( $D = 2.5 \text{ mm}$  and  $l = 6 \text{ mm}$ ). The recommended mounting torque is  $0.4 \text{ Nm}$ . (See the package drawing for detailed dimensions of the board.) The through-hole diameters on the PCB have to be designed according to the pin dimensions detailed in the package drawing. In case of soldering, all pins must be soldered after mounting the module to the PCB.



## 2.1 Specification for modules with Press-fit pins that are soldered to the PCB

In cases where the Press-fit pins are soldered instead of pressed into the PCB the recommended PCB hole diameter is  $1.45 \text{ mm} \pm 0.1 \text{ mm}$ . In these cases, the annular ring must be designed according to the standards for through hole components to ensure proper soldering of the Press-fit pins. Please read section 9 Recommendation for soldering also.

## 3 Specifications for baseplate

The thermal properties are not affected if the dimensions of the surface imperfections are within the following values.

- Polishing is allowed on the whole nickel plated surface if copper doesn't become visible.
- If copper becomes visible, the unit is scratched and following the acceptance criteria should be used. The depth and width of the scratch can't exceed  $200 \mu\text{m}$  and  $800 \mu\text{m}$ , respectively. The length of the scratch does not matter but the total area of scratches must not exceed 5 % of the total substrate surface.

Discolorations and fingerprints are only surface imperfections and do not affect the module's functionality. Substrate surface imperfections can be seen on Figure 3 and Figure 4.

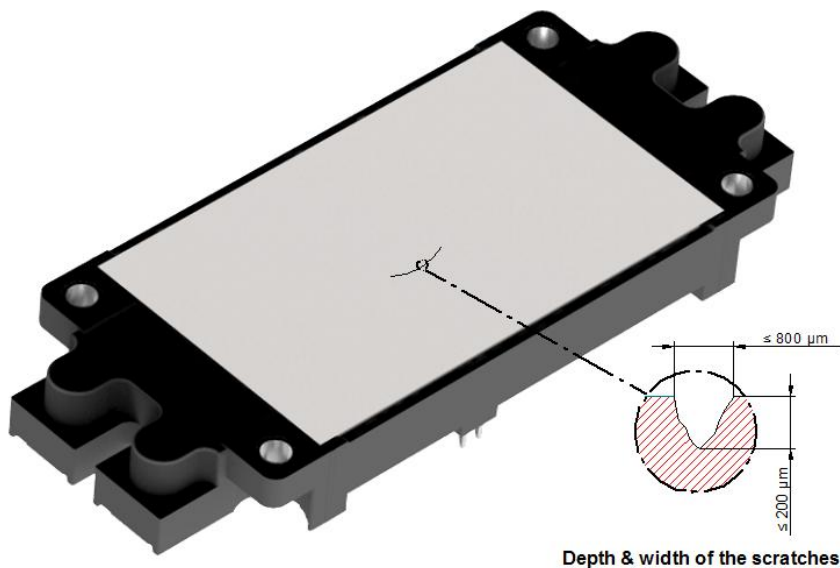

Figure 3: Scratch dimensions

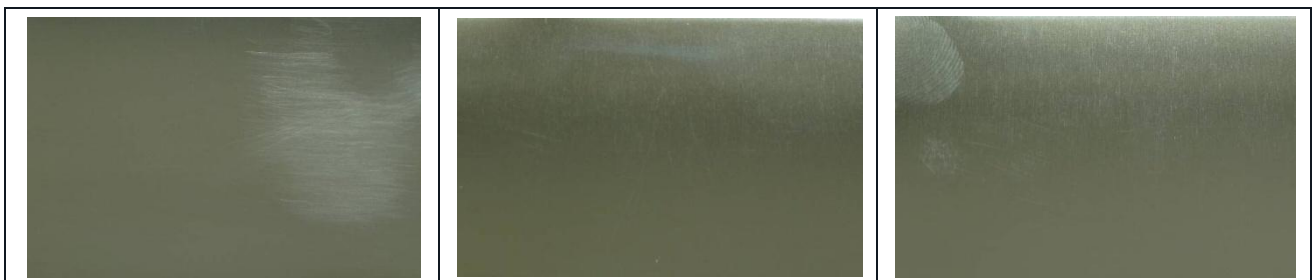

Figure 4 (left to right): Polished surface; Discoloration; Fingerprint



## 4 Specifications for heat sink

The whole heat sink surface under the module must be plane, clean and free of particles.

- The flatness tolerance should be:  $<50 \mu\text{m}$  in general. (A flatness tolerance specifies a tolerance zone defined by two parallel planes within which the surface must lie.)
- The surface roughness should be less than:  $R_z < 10 \mu\text{m}$ .
- Heat sink surface imperfections should be within the values described for the module baseplate surface (please refer to section 3 Specifications for baseplate).

## 5 Specifications for thermal interface materials

The recommended means of applying paste is screen printing. Thermal resistance ( $R_{th}$ ) increases if the paste is thicker than recommended. Modules are also available with phase change material (OPTION 2), whereby the  $R_{th(c-s)}$  is given, provided that the heat sink specification remains unchanged.

### 5.1 OPTION 1: Thermal paste

- A. The advised technology for paste application is screen printing. Applying an inhomogeneous layer of thermal conductive paste in a honeycomb pattern is the preferred solution. For the drawing of the honeycomb pattern please contact your local sales representative.

Module type	Thermal paste (Wacker P12)
VINco E3	100 – 140 $\mu\text{m}$

Table 1: Thermal paste thickness

- B. Alternatively a roller or spatula can be used to apply a homogeneous layer of thermal conductive paste over the whole backside of the module,

Any different paste application technology or type of thermal paste should be tested additionally. The mounting procedure for modules is the same as the standard mounting process described in Section 6.

### 5.2 OPTION 2: Pre applied thermal interface material

The VINco E3 may have already been pre-printed with phase change thermal interface material. Once the compound is applied, it is dried to a solid phase change material. The material will only flow above the phase change temperature of 45 °C when pressure is applied.

- No burn-in is necessary to melt the phase change material. Upon flow, air is expelled from the interface and the material conforms to the surface features of the heat sink and power module. Reducing thermal impedance, the material performs as a highly efficient thermal transfer material.
- The mounting procedure is the same as the standard mounting process; screws to the heat sink can be fastened and tightened in one single step. The phase change material is solid at room temperature, so screws can be tightened immediately without having to give the material any relaxation time.
- Further information about using modules with pre-applied TIM see the application note for "Power modules with Phase-Change Material" on Vincotech's website

In case of modules with Press-fit pins a unique press-in tool (see Figure 7) has to be used. This way the module can be mounted to the heat sink after it has been pressed into the PCB. It is also possible to mount the module to the heat sink and then press the PCB onto the assembly.



The mounting procedure for modules is the same as the standard mounting process described in Section 6.

Module type	Phase change (Loctite PSX-Pm)
VINco E3	100 – 140 $\mu\text{m}$

Table 2: Phase change material thickness

## 6 Specifications for fastening screws to the heat sink

- Screws M5 (recommended screw type DIN 7984)
- Flat washer D=max. 10 mm ISO 7092 (DIN 433)
- Spring washer D=max. 10 mm DIN127 or DIN 128
- Mounting torque:  $2.5 \text{ Nm} < M_a < 3.5 \text{ Nm}$
- Thread length into the heat sink: min. 9 mm

A torque wrench shall be used to tighten the mounting screws. Excessive torque may result in damage or degradation of the device. The inaccuracy of torque wrench has to be taken into account to prevent over-tightening the fastener.

Due to excessive temperature fluctuations washers should be used to prevent the loosening of the screws. After accurate tightening the spring washer exerts a constant force on the joint, while the flat washer distributes this force on the surface.

Tighten screws in the sequence given below and shown in Figure 5. It is recommended to limit the tightening speed below 450 rpm in order to prevent damage to the plastic parts of the module.

- 1) Attach the module loosely with two diagonal screws e.g. 1 & 4.
- 2) Tighten screws with 0.5 Nm torque in the following sequence: 1 – 4 – 2 – 3.
- 3) Tighten the screws with final mounting torque in the same sequence.



Figure 5: Screw positions in sequence

## 7 Screw specification for fastening main terminals to bus bars

- M6 screw: The threaded-hole's depth in the module is max. 12.5 mm from the main terminal's topside. (See the package drawing for detailed dimensions.)
- Material: Steel grade 6.8 or better
- Mounting torque:  $3.5 \text{ Nm} < M_a < 4.5 \text{ Nm}$
- Flat washer: ISO 7092 (DIN 433)
- Spring washer: DIN127 or DIN 128

The spring washer exerts a constant force on the joint while the flat washer distributes this force on the contact surface.



## 8 Press in process of modules with Press-fit pins

### 8.1 Press-in construction

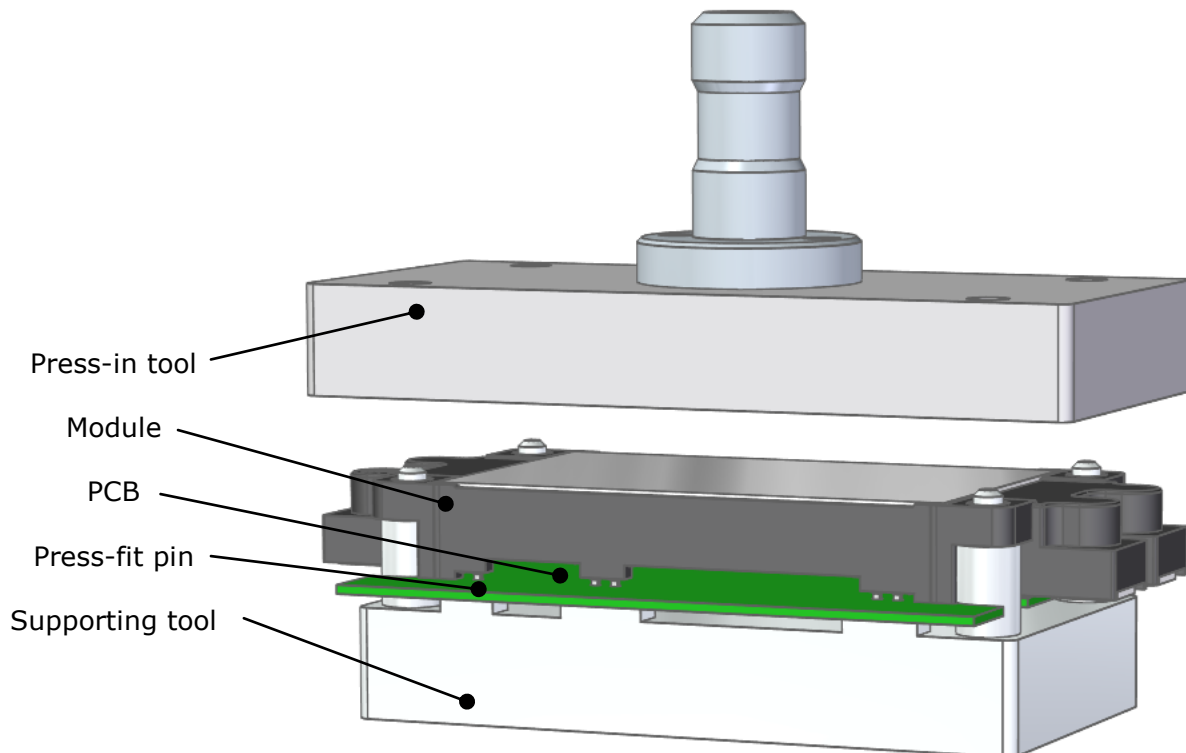

Figure 6: Recommended setup for press-fitting

The preferred process method is to press the module into the PCB from the top (as Figure 6 shows) alternatively the PCB can be pressed onto the module from the top (the module is below the PCB). The former method will be discussed in this document.

In any case the tool has to ensure the correct leveling of the module and PCB to avoid mechanical stresses during assembly. The minimum distance for components from the pressing tool on the PCB is 4 mm. Inserting multiple modules into one PCB can be done one by one, or all at once. Pressing multiple modules at the same time requires a press-in tool according to the above detailed single tool. Assembly steps explained:

- 1) Put the printed circuit board on the supporting tool.
- 2) Temporarily set the Module on the PCB and position the tip of the press-fit pins to the location of the through holes.
- 3) Apply the required press-in force on the module with the press-in tool. The applied force should be limited not to put overload on the PCB. Refer to Section 8.2.
- 4) The position should be controlled and the motion of the tool should be stopped when the PCB touches the standoffs of the Module.

The correct leveling of the modules can also be achieved with a position-controlled press-in machine. The press-in process has to be controlled according to the requirements stated in section 8.2.



### 8.1.1 Press-in tool for modules without thermal interface material

Recommended material for the press-in tool:

- Tempered aluminum alloy grade 7075-T6 with 430 MPa yield strength and 160 HB hardness or
- Steel-grade 21MnCr5 with 660 MPa yield strength and 330 HB or better hardness

### 8.1.2 Modules with thermal interface material

A unique press-in top shown in Figure 7 is needed to prevent significant damage to the phase change material during the press-in process.

Requirements for the press-in tool:

- Material: tool steel grade 21MnCr5 with yield strength of 660 MPa and hardness of 330 HB or better.
- Maintenance: Due to inherent contamination from process and product tolerance differences, it is recommended to clean the press-in tool regularly. The desired cleaning interval is once every 100 modules with soft wipes soaked in Isopropyl alcohol.

For more information or a 3D model please contact your local sales manager.

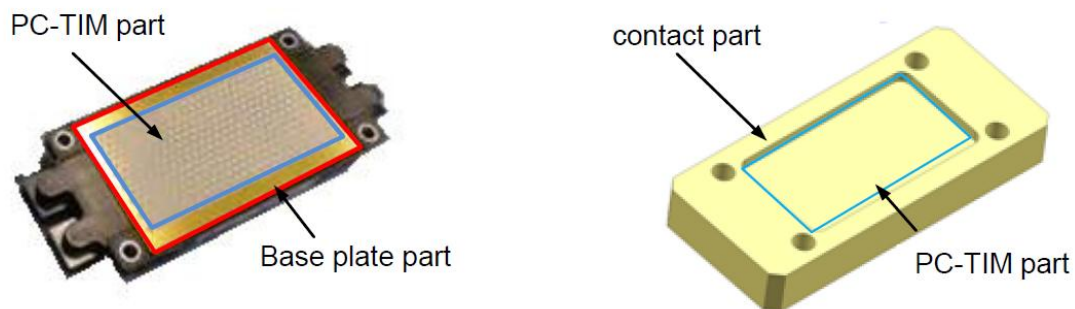

Figure 7: Module with PC-TIM (left); Press-in tool for modules with PC-TIM (right)

### 8.1.3 Supporting tool

The support plate positions and supports the module during press-fitting. The recommended material for the support plate is ESD-proof POM (polyoxymethylene) or any metal alloy.

The recommended diameter of holes/ cutouts for the pins is 1.7 mm to 4 mm, depending on positioning accuracy, as shown on

Figure 8. Allow for at least 1.7 mm supporting space around the pin. The PCB and module must also be positioned. The size and position of holes and cutouts is determined by the components on the PCB. Cutouts for pins should be 6 mm deep.

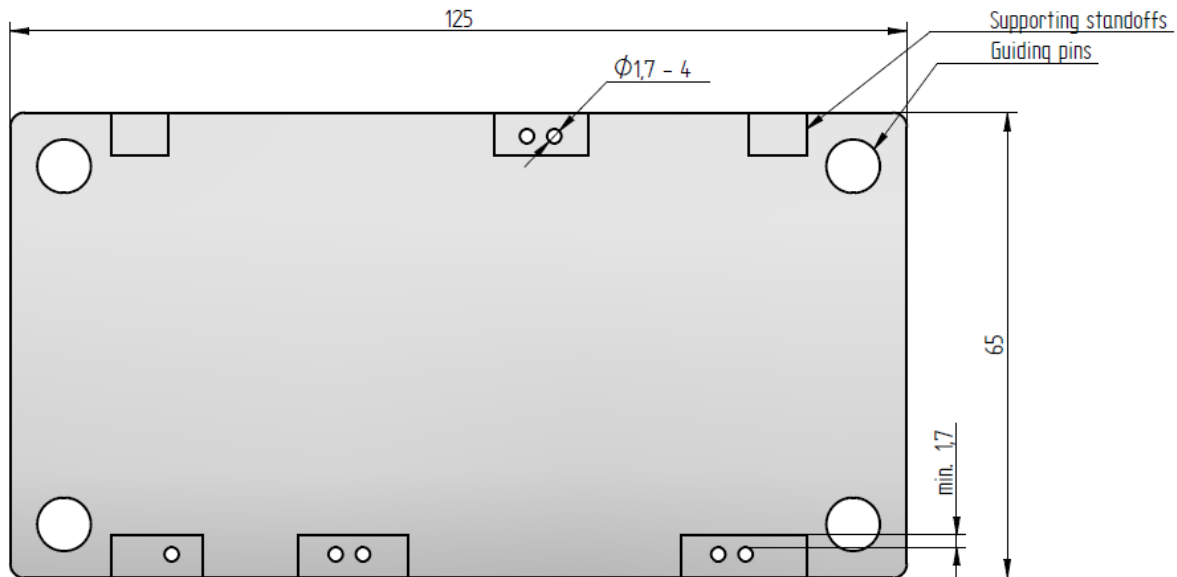

Figure 8: Recommended dimensions for the press-in supporting tool

## 8.2 Press-fit process control parameters

The total press-in force depends on the number of pins, through-hole diameter and plating (type/quality) of the PCB.

- Press-in force: 20 N / pin – 120 N / pin
- Press-in speed: 25 - 450 mm / min

If the press machine is equipped with the possibility to record the force-stroke values during the process, the following quality relevant values should be taken into consideration. Figure 9 shows a typical press-in diagram.

Three different sections can be seen on the diagram:

- First, raising section (I.): The heads of the Press-fit pins slide into the holes and deform to fit in the holes. This section ends with a local maximum.
- Second section (II.): The pin slides in the holes to reach the final position. The centre of the pin heads are inside the holes and do not deform any longer.
- Third, raising section (III.): press-in tool touches the PCB and the sliding of the pins is stopped. As the tool abuts on the PCB the force raises sharply.

Possible process control parameter settings are as follows:

- The local maximum value (middle of second section) of the force-stroke diagram has to be:
  - higher than the lower limit insertion force times the number of the pins and,
  - smaller than the upper limit insertion force times the number of the pins.
- In order to avoid any damage to the PCB the press-in force of the tool has to be controlled to stop the process during the third, raising section. The force control should stop at the upper limit insertion force times the number of the pins.

If the press-in force does not fit in the interval defined above, it can indicate faulty plating, or improper diameter of the holes.

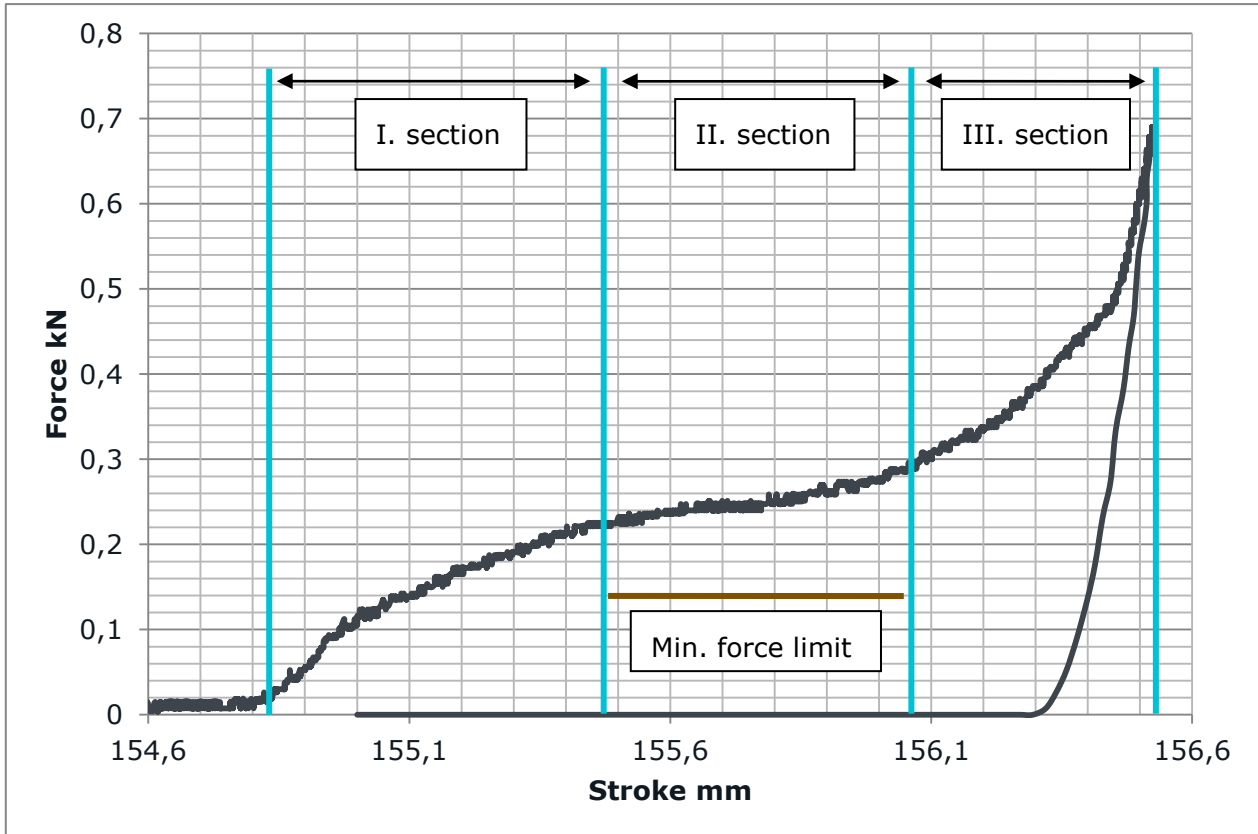

Figure 9: Typical press-in diagram of a module with 7 pins

## 8.3 Disassembling a driver PCB

### 8.3.1 PCB larger than Module

An automatic press machine or a hand press can be used to disassemble the module and driver PCB. The recommended tooling and setup of the tools and module can be seen on Figure 10: Recommended setup for disassembly. Disassembly steps:

- 1) Screw down the module to the fixed jig using M5 screws recommended in Section 6.
- 2) Apply the required press-out force on the module with the press-jig.
- 3) The nail part of the jig will push the PCB and remove it from the Module. The position of the nail parts should be as close to the pins as possible.

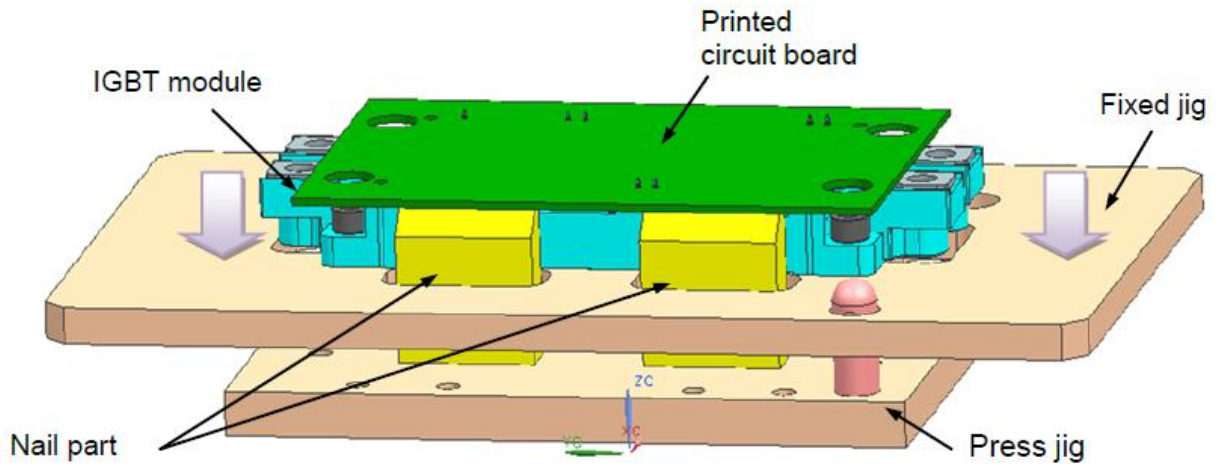

Figure 10: Recommended setup for disassembly

The total press-out force depends on the number of pins, through-hole diameter and plating (type/quality) of the PCB:

- Press-out force: min. 20 N / pin
- Press-out speed: max. 12 mm / min

A typical force-distance diagram of the press-out process is shown for an 11 pin module on Figure 11. This curve starts with a characteristic peak, which indicates the breaking of the cold welded connection.

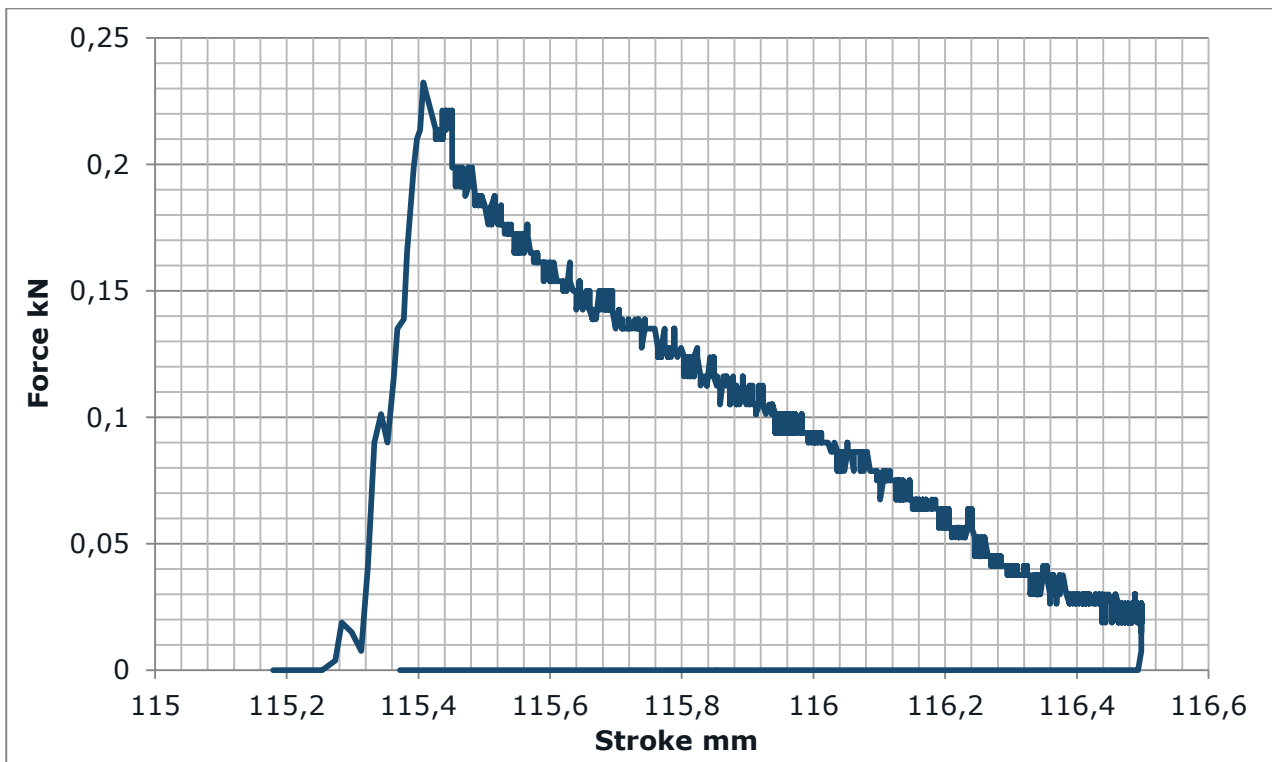

Figure 11: Typical press-out diagram of a module with 7 pins



### 8.3.2 PCB not larger than Module

If the driver PCB is no larger than the module, the PCB cannot be disassembled by pressing it out. In this case, the only way to remove the PCB is to cut the pin ends. Manual disassembly with pliers is an option if the Press-fit pinhead is overlapped by the PCB so that the eye-of-the-needle end projects out of the PCB. Ensure you cut at plane indicated in Figure 12 below where the two parts of the pinhead come together. Remove the driver PCB from the module after clipping off all pinheads.

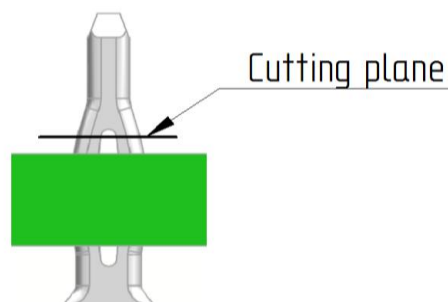

Figure 12: Cutting edge

## 9 Recommendation for soldering

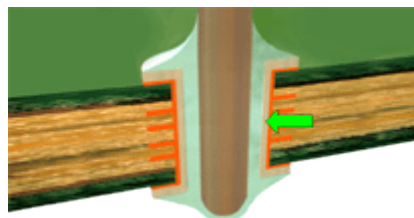

Figure 13: Plated through hole, well soldered

Plated through holes should exhibit a vertical solder fill of 75 %, with a fully formed fillet on the solder side and evidence of 75 % wetting on the component side lead, barrel and pad.

## 9.1 Wave soldering of modules with solder pins

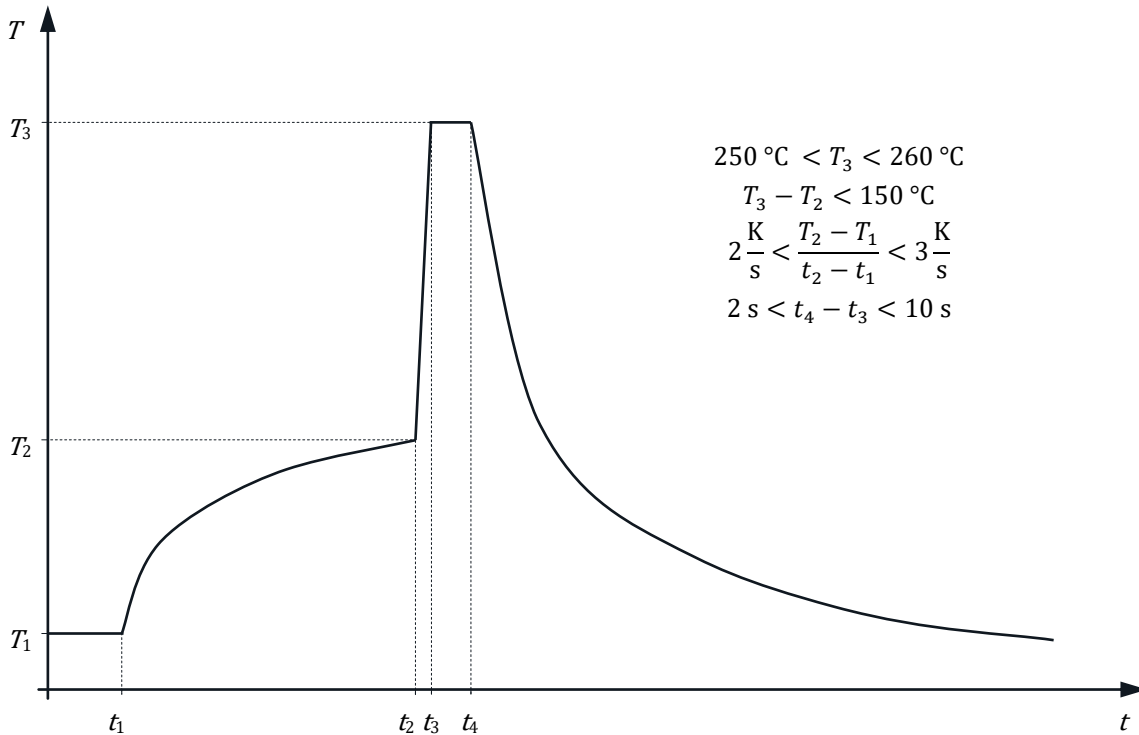

Figure 14: Typical profile for wave soldering

Soldering of certain modules with Press-fit pins is also possible using wave soldering process. Wave soldering cannot be performed on all type of Press-fit modules.

## 9.2 Hand soldering parameters

- Max. solder iron temperature: 350 °C
- Max. contact time with component lead: 10 s
- Number of heat cycles: 3

## 10 ESD protection

Modules are sensitive to electrostatic discharge which can damage or destroy sensitive semiconductors. All modules are ESD protected in the shipment box by semi conductive plastic trays. During the handling and assembly of the modules it is recommended to wear a conductive grounded wrist band and ensure a conductive grounded working place.

Please take into consideration the following standards for handling electrostatic-sensitive devices: EN61340-5-1, ANSI S20.20



## 11 Environmental conditions

The modules can be subjected to environmental conditions defined in the IEC 60721-3-1, IEC 60721-3-2 and IEC 60721-3-3 standards and characterized by the following classes:

Storage:	1K2 / 1B1 / 1C1 / 1S2 / 1M2
Transportation:	2K2 / 2B1 / 2C1 / 2S1 / 2M2
Operation:	3K3

The above mentioned storage conditions should be assured for the recommended storage time of maximum 2 years.

Flammability classification of the plastic materials for all VINco E3 are V-0 and 5-VA (self-extinguishing, no dripping of flaming particles) according to UL 94, IEC 60695-11-10 and IEC 60695-11-20 test methods.

### 11.1 Storage, transportation and operation conditions

The parameters detailed below are for informative purposes only. This section does not substitute the above mentioned standards. Please read the IEC 60721-3-1, IEC 60721-3-2 and IEC 60721-3-3 standards for the full description of the environment classes.

#### 11.1.1 Climatic conditions

##### 1K2

Air temperature:	5 °C to 40 °C
Humidity:	5 % to 85 % RH but max. 1 g/m <sup>3</sup> to 25 g/m <sup>3</sup> absolute
Rate of change of temperature:	0.5 °C/min
Air pressure:	70 kPa to 106 kPa
Solar radiation:	700 W/m <sup>2</sup>
Movement of surrounding air:	1 m/s
Condensation:	No
Precipitation:	No
Water from other sources than rain:	No
Formation of ice and frost:	No

##### 2K2

Temperature:	-25 °C to 60 °C
Change of temperature air/air:	±25 °C
Relative humidity not combined with rapid temperature changes:	max. 75 % (at 30 °C temperature)
Relative humidity combined with rapid temperature changes:	No
Low air pressure:	70 kPa
Change of air pressure:	No
Solar radiation:	700 W/m <sup>2</sup>
Movement of surrounding air:	No
Precipitation:	No
Heat radiation:	No
Water from other sources than rain:	No
Wetness:	No





3K3

Relative humidity: 5% to 85%

Absolute humidity: 1 g/m<sup>3</sup> to 25 g/m<sup>3</sup>

Condensation: No

Precipitation: No

Formation of ice: No

### 11.1.2 Biological conditions

1B1

Flora and fauna: Negligible

2B1

Flora and fauna: No

### 11.1.3 Chemically active substances

1C1

Sea and road salts: No (Salt mist may present in sheltered locations of coastal areas.)

Sulphur dioxide: 0.1 mg/m<sup>3</sup>

Hydrogen sulphide: 0.01 mg/m<sup>3</sup>

Chlorine: 0.01 mg/m<sup>3</sup>

Hydrogen chloride: 0.01 mg/m<sup>3</sup>

Hydrogen fluoride: 0.003 mg/m<sup>3</sup>

Ammonia: 0.3 mg/m<sup>3</sup>

Ozone: 0.01 mg/m<sup>3</sup>

Nitrogen oxides: 0.1 mg/m<sup>3</sup> (Expressed in equivalent values of Nitrogen dioxide.)

2C2

Sea salts: none

Sulphur dioxide: 0.1 mg/m<sup>3</sup>

Hydrogen sulphide: 0.01 mg/m<sup>3</sup>

Nitrogen oxides: 0.1 mg/m<sup>3</sup> (Expressed in equivalent values of Nitrogen dioxide.)

Ozone: 0.01 mg/m<sup>3</sup>

Hydrogen chloride: 0.1 mg/m<sup>3</sup>

Hydrogen fluoride: 0.003 mg/m<sup>3</sup>

Ammonia: 0.3 mg/m<sup>3</sup>

### 11.1.4 Mechanically active substances

1S2

Sand: 30 mg/m<sup>3</sup>

Dust (suspension): 0.2 mg/m<sup>3</sup>

Dust (sedimentation): 1.5 mg/(m<sup>2</sup>\*h)

2S1

Sand in air: No

Dust (sedimentation): No

### 11.1.5 Mechanical Conditions

1M2

Stationary vibration, sinusoidal



Frequency range: 2 Hz to 9 Hz  
displacement amplitude: 1.5 mm  
Frequency range: 9 Hz to 200 Hz  
peak acceleration: 5 m/s<sup>2</sup>

Non stationary vibration, including shock

Shock response spectrum type L

peak acceleration: 40 m/s<sup>2</sup>

Static load: 5 kPa

2M2

Stationary vibration, sinusoidal

Frequency range: 2 Hz to 9 Hz

displacement amplitude: 3.5 mm

Frequency range: 9 Hz to 200 Hz

peak acceleration: 10 m/s<sup>2</sup>

Frequency range: 200 Hz to 500 Hz

peak acceleration: 15 m/s<sup>2</sup>

Stationary vibration, random

Acceleration spectral density: 1 m<sup>2</sup>/s<sup>3</sup>

Frequency range: 10 Hz to 200 Hz

and

Acceleration spectral density: 0.3 m<sup>2</sup>/s<sup>3</sup>

Frequency range: 200 Hz to 2000 Hz

The later range can be neglected transporting with vehicles with high damping.

Non stationary vibration, including shock

Shock response spectrum type I.

peak acceleration: 100 m/s<sup>2</sup> , and

Shock response spectrum type II.

peak acceleration: 300 m/s<sup>2</sup>

Free fall: Internal standard F23047-A1004-S000-01-76

Toppling: Around any of the edges.

Rolling, pitching

Angle: ±35°

Period: 8 s

35° may occur for short time periods but 22.5° may persist permanently.

Acceleration 20 m/s<sup>2</sup>

Static load 10 kPa



### 11.2 Handling of trays

The modules are transported in layer of trays and every layer has to be rotated on each other by 180° to guarantee the safety of all modules. This is also valid any time after unpacking. Figure 15 shows the trays in wrong and in good position.

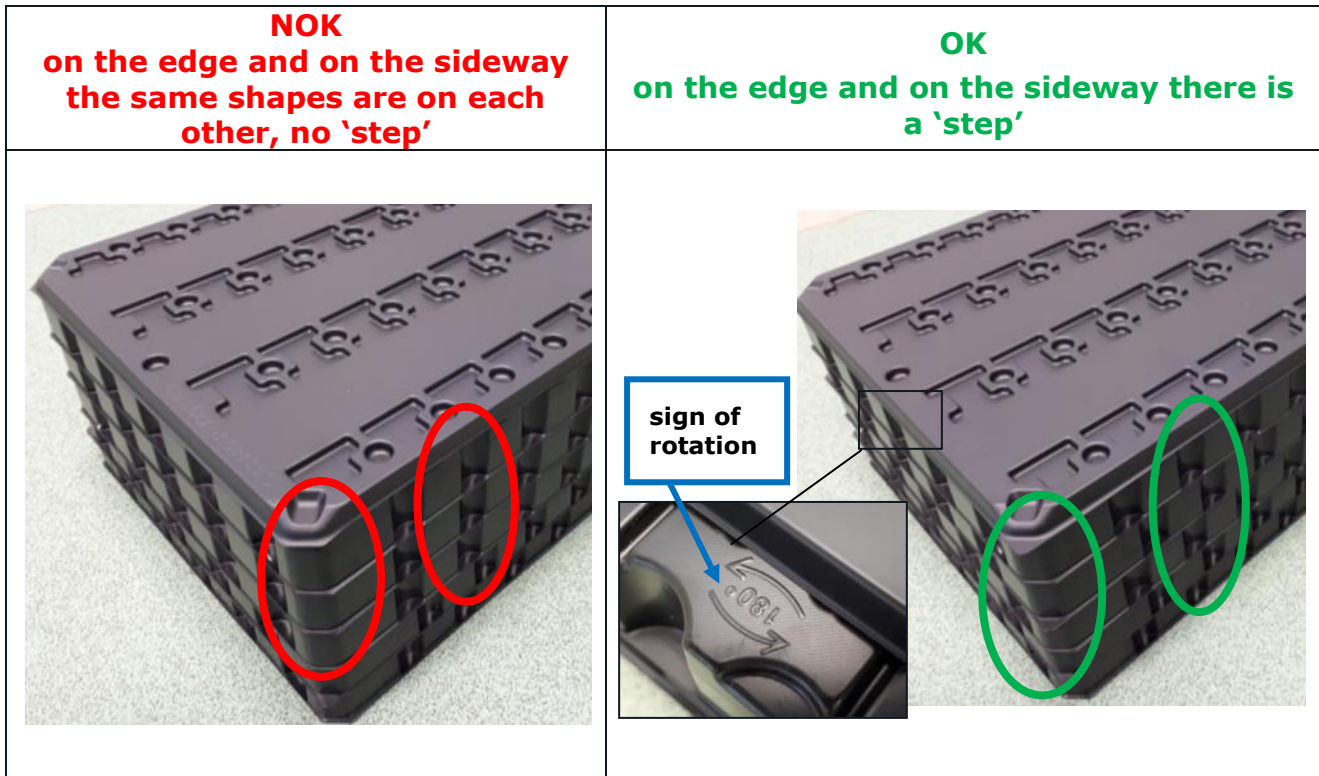

Figure 15: Layer of trays

## 12 Disclaimer

The information and recommendations in this document are based on standards and common engineering practices. Customer specific applications and specifications may require additional processes and tests that may supersede those recommended in this document.